

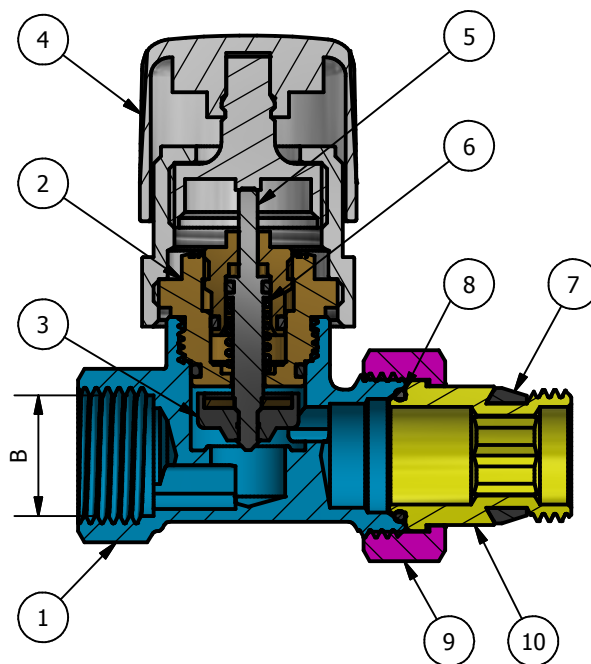

A-A (1 : 1.2)

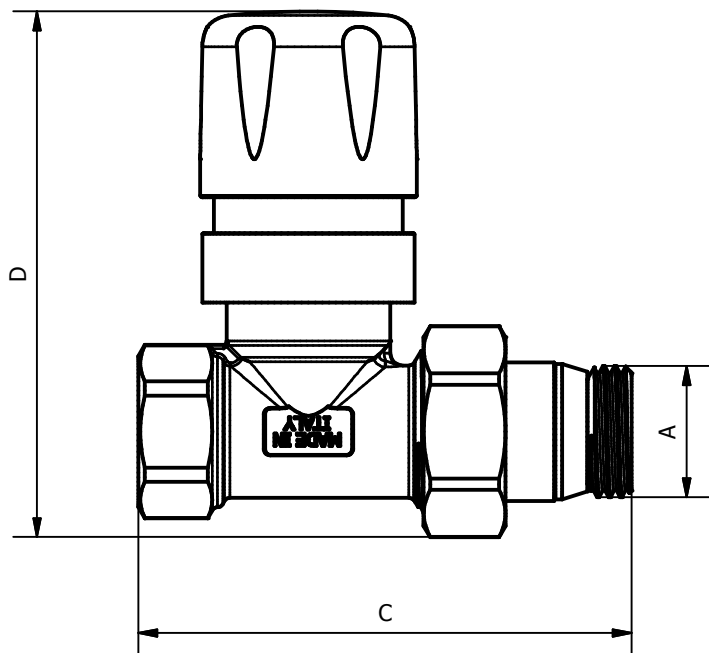

CODICE	A	B	C	D
VDTFTS GC 3838	3/8	3/8	78,5	83
VDTFTS GC 1212	1/2	1/2	78,5	83

WORKING PRESSURE MAX	10 BAR
TEMPERATURE RANGE MIN-MAX	0°C +95°C

N°	Description	Material
1	Body	CW 617N EN12165
2	Command Screw	CW 614N EN12164
3	Flat Rubber	NBR 80
4	Handle	ABS
5	Stem	CW 614N EN12164
6	Spring	AISI 302
7	Rubber	EPDM 70
8	O-ring	NBR 70
9	Nut	CW 617N EN12165
10	Tang	CW 617N EN12164

00	Prima emissione	Delaini M.	19/07/2018
Rev.	Nota Revisione	Approvatore	Data Approvazione
Toll Gen:	JS13	Stato sup.:	Nichelato
Filetto:	ISO 228	Note tecniche:	
Peso lavorato:	Peso grezzo:	N° stampo:	
Materiale:		Disegnatore:	Data: 18/07/2018
		Delaini P.	
Codice: VDTFTS GC scheda		Descrizione: Straight thermostatic valve with pre-setting	
TDM Brass s.r.l via Artigiani , 7-9 25030 Maclodio BS Italy tel +39 030 9972217 fax 030 9787089 www.tdmbrass.it email info@tdmbrass.it		 <i>Italian Thermo</i>	